

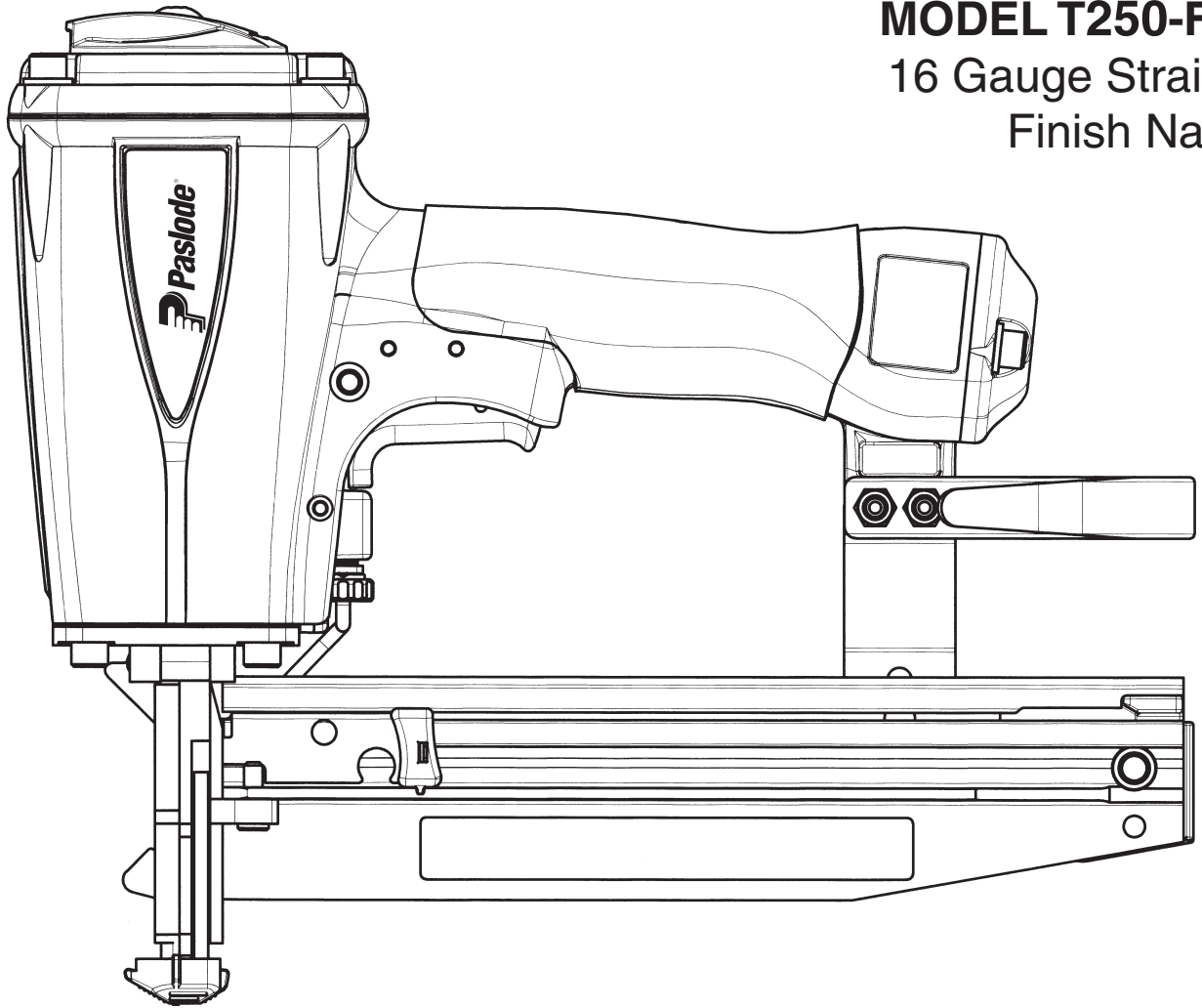

**MODEL T250-F16**  
16 Gauge Straight  
Finish Nailer



**IMPORTANT!**  
DO NOT DESTROY

It is the customer's responsibility to have all operators and service personnel read and understand this manual.

**OPERATING MANUAL AND  
SCHEMATIC**

# INTRODUCTION

The **PASLODE® T250-F16** finish nailer is a quality-built tool designed for use in residential trim applications. This tool will deliver efficient, dependable performance when used according to the manufactures guidelines. Please study this manual including the safety instructions to fully understand the operation of this tool.

<b>TOOL AND FASTENER SPECIFICATIONS .....</b>	<b>3</b>
<b>SAFETY INSTRUCTIONS .....</b>	<b>4</b>
<b>INSTRUCTIONS FOR LOADING .....</b>	<b>5</b>
<b>EXPLODED VIEW AND SPARE PARTS LIST .....</b>	<b>6</b>
<b>ACCESSORIES .....</b>	<b>8</b>

## TOOL WARRANTY AND LIMITATIONS

Paslode warrants that newly purchased power fastening tools parts and accessories will be free from defects in material and workmanship (excluding wear parts) for the period shown below, after the date of delivery to the original user.

### 90-DAY LIMITED WARRANTY

A 90-day warranty will apply to all parts, except those which are specifically covered by an extended warranty.

### EXTENDED LIMITED WARRANTY FOR ON SITE CONSTRUCTION APPLICATIONS

A one year warranty will apply to all housing and cap assembly castings. A six month warranty will apply to all magazines parts.

### NORMAL WEARING PARTS

The following parts are considered normal wearing parts and are not under warranty:

- Bumper
- Drive Blades
- "O" Rings
- Piston Rings

### WARRANTY STATEMENT

Paslode's sole liability hereunder will be to replace any part or accessory which proves to be defective within the specific time period. Any replacement part or accessory provided in accordance with this warranty will carry a warranty for the balance of the period of warranty applicable to the part it replaces.

This warranty is void as to any tool which has been subjected to misuse, abuse, accidental or intentional damage, used with fasteners not meeting Paslode specification, size, or quality, improperly maintained, repaired with other than genuine Paslode replacement parts, damaged in transit or handling, or which, in Paslode's opinion, has been altered or repaired in a way that affects or detracts from the performance of the tool.

PASLODE MAKES NO WARRANTY, EXPRESSED OR IMPLIED, RELATING TO MERCHANTABILITY, FITNESS, OR OTHERWISE, EXCEPT AS STATED ABOVE, and Paslode's liability AS STATED ABOVE AND AS ASSUMED ABOVE is in lieu of all other warranties arising out of, or in connection with, the use and performance of the tool, except to the extent otherwise provided for by applicable law. PASLODE SHALL IN NO EVENT BE LIABLE FOR ANY DIRECT, INDIRECT, OR CONSEQUENTIAL DAMAGES, INCLUDING, BUT NOT LIMITED TO, DAMAGES WHICH MAY ARISE FROM LOSS OF ANTICIPATED PROFITS OR PRODUCTION, SPOILAGE OF MATERIALS, INCREASED COST OF OPERATION, OR OTHERWISE.

Paslode reserves the right to change specifications, equipment, or designs at any time without notice and without incurring obligation.

## TOOL AND FASTENER SPECIFICATIONS

### TOOL SPECIFICATIONS

MODEL NO.	T250-F16 (Part# 500970)
HEIGHT	10"
WIDTH	3-1/8"
LENGTH	12"
WEIGHT	4lbs. 2oz.
OPERATING PRESSURE	80 to 120 p.s.i. (5.5 to 8.3 bars)

### FASTENER SPECIFICATIONS

NAIL LENGTH	3/4" - 2-1/2"
SHANK DIAMETER	16 gauge

### TOOL AIR FITTINGS:

This tool uses a 1/4" N.P.T. male plug. The inside diameter should be .28" (7mm) or larger. The fitting **must** be capable of discharging tool air pressure when disconnected from the air supply.

### OPERATING AIR PRESSURE:

80 to 120 p.s.i. (5.5 to 8.3 bars). Select the operating air pressure within this range for best tool performance.

**DO NOT EXCEED THIS RECOMMENDED OPERATING PRESSURE.**

# SAFETY INSTRUCTIONS

## SAFETY FIRST

These safety instructions provide information necessary for safe operation of Paslode® tools. **DO NOT ATTEMPT TO OPERATE THE TOOL UNTIL YOU READ AND UNDERSTAND ALL SAFETY PRECAUTIONS AND MANUAL INSTRUCTIONS.**



### WEAR EYE AND HEARING PROTECTION

Always wear hearing and eye protection devices, that conform to ANZI Z87.1 requirements, when operating or working in the vicinity of a tool. As an employer you are responsible for enforcing the use of eye protection. Wear hard hats in environments that require their use.

### THE TOOL MUST BE USED ONLY FOR THE PURPOSE FOR WHICH IT WAS DESIGNED

Do not throw the tool on the floor, strike the housing in any way or use the tool as a hammer to knock material into place.

### NEVER ENGAGE IN HORSEPLAY WITH THE TOOL

The tool is not a toy so do not use it like one. Never engage in horseplay with the tool or point it at yourself or any other person, even if you think it is not loaded.

### NEVER ASSUME THE TOOL IS EMPTY

Check the magazine for fasteners that may be left in the tool. Even if you think the tool is empty or disconnected, never point it at anyone or yourself. Unseen fasteners could fire from the tool.

### NEVER CLAMP THE TRIGGER IN A LOCKED OR OPERATING POSITION

The trigger of the tool must never be tampered with, disabled or clamped in a locked or operating position since this will cause the tool to drive a fastener any time the work contacting element depressed.

### DO NOT LOAD FASTENERS WITH THE AIR LINE CONNECTED, OR WITH THE TOOL TRIGGER OR WORK CONTACTING ELEMENT DEPRESSED

When loading fasteners into the tool be sure you disconnect the air line and that you do not depress the trigger or work contacting element.



### OPERATE THE TOOL ONLY ON A WORKPIECE

The tool should be operated only when it is in contact with the workpiece. Even then you should be careful when fastening thin material or working near the edges and corners of the workpiece since the fasteners may drive through or away from the workpiece.

### DO NOT DISABLE OR REMOVE THE WORK CONTACTING ELEMENT

This tool is equipped with a safety mechanism, called a work contacting element, to help prevent accidental firing. Never tamper with, disable or remove the work contacting element. Do not use the tool unless the work contacting element is working properly. The tool could fire unexpectedly.

### DISCONNECT THE TOOL WHEN NOT IN USE

Always disconnect the tool from the air line when it is not in use, when you leave the work area or when moving the tool to a new location. The tool must never be left unattended because people who are not familiar with the tool might handle it and injure themselves or others.



### CARRY THE TOOL ONLY BY THE HANDLE

Always carry the tool by the handle only. Never carry the tool by the air hose or with the trigger depressed since you could drive a fastener unintentionally and injure yourself or someone else.

### DO NOT WEAKEN THE TOOL HOUSING

The tool housing is a pressure vessel and should never be weakened by having your company's name, area of work or anything else stamped or engraved into its surface.

### DISCONNECT THE TOOL WHEN PERFORMING REPAIRS AND CLEARING JAMS

Never attempt to clear a jam or repair a tool unless you have disconnected the tool from the air line and removed all remaining fasteners from the tool.

### ALWAYS USE THE PROPER FITTING FOR THE TOOL

Only MALE pneumatic type air connectors should be fitted to the tool, so that high pressure air in the tool is vented to atmosphere as soon as the air line is disconnected.

NEVER install FEMALE quick disconnect couplings on the tool. Female couplings will trap high pressure air in the tool when the air line is disconnected, leaving the tool charged and able to drive at least one fastener.



### DO NOT EXCEED THE MAXIMUM RECOMMENDED AIR PRESSURE

Operate the tool only at the recommended air pressure. Do not exceed the maximum air pressure marked on the tool. Be sure the air pressure gauge is operating properly and check it at least twice a day.

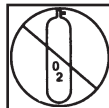

Never use any bottled air or gases such as oxygen to operate the tool since they could cause the tool to explode.

### INSPECT TOOL FOR PROPER OPERATION

Clean the tool at least daily and lubricate as required. Never operate a dirty or malfunctioning tool.

### USE ONLY PASLODE RECOMMENDED PARTS AND FASTENERS

Use only parts and fasteners specifically designed and recommended by Paslode for use in the tool and for work to be done. Using unauthorized parts and fasteners or modifying the tool in any way creates dangerous situations. Replace all missing warning labels---refer to tool schematic for correct placement and part number.

## **⚠ WARNING**

Failure to follow any of the above instructions could result in severe personal injury to tool user and bystanders or cause damage to tool and property.

Contact your local Paslode Representative for presentation of Paslode's Safety Awareness Program

# T250-F16 FEATURES & BENEFITS

## Adjustable

### Exhaust Cap

Direct exhaust where you want it. Avoid dust!

### Powerful Motor

Drive 16 gauge finish nails from 3/4" to 2 -1/2" offering versatility for many applications.

### Compact

### Lightweight Design

Only 4.3 lbs. and able to get into tight spots.

### Adjustable Depth of Drive

Provides precise control of nail depth into hard or soft wood.

### Quick Clear Nose

Easy access to possible nail jams. (opposite side)

### Narrow Long Nose

Precise placement of nails.

### No-Mar Tip

### With Site Lines

Prevents damage to expensive trim. Clear line of sight.

### Ergonomic Handle with Sure Grip

Comfortable design and suregrip provide more control and less fatigue.

### Reversible Belt Hook

Hang your tool on your belt or ladder for overhead work.

### Two Finger Trigger

Provides less fatigue and more control.

### Top Load Magazine

Insert nails down into the channel. Holds 2 strips or 100 nails.

### Reload Indicator

View quickly when nails are needed.

### Ergonomic Magazine Release

Quick and easy loading.

**USE ONLY  
16 GAUGE STRAIGHT  
FINISH NAILS**

## **Loading Instructions:**

**Step No. 1** – Pull back the magazine release.

**Step No. 2** – Insert 16 gauge straight finish nails down into the magazine.

**Step No. 3** – Move magazine release forward.

# PARTS LEGEND

# T250-F16, 500970

1	501043	1	T.H.S.C.S. 1/4-20 x 1/2	43	403812	2	Flat Washer
2	500956	1	Cap Diffuser	44	004238	2	Lock Washer
3	501299	6	S.H.C.S. 1/4-20 x 1	45	004224	2	S.H.C.S. - 10-32 x 3/8
4	403582	1	Jam Nut	46	500458	1	Warning Label
5	500958	1	Cap	*47	500772	1	Spring, W.C.E.
6	402717	1	Conical Spring	48	501143	1	Intermediate W.C.E.
7	404230	1	Retaining Ring	49	500766	1	Guide Block
8	404122	1	Upper Valve Piston	50	071297	1	Roll Pin 1/8 x 1-1/8
* 9	091537	1	O-Ring, Main Valve Assembly	51	500840	1	W.C.E. Assembly
10	404054	1	Seal, Main Valve	52	404180	1	Probe Tip
11	404056	1	Lower Valve Piston	53	404698	2	Roll Pin Assembly
* 12	090927	1	O-Ring, Main Valve	54	402730	1	Pivot Pin, front Guide
* 13	092775	1	O-Ring, Main Valve	55	403592	1	Front Guide
* 14	092773	1	O-Ring, Main Valve	56	403591	1	Back Plate
* 15	404256	2	O-Ring, Valve Post, End Plug	57	501023	1	Grip Handle
16	500954	1	Post Main Valve	58	080326	2	S.H.C.S. 10-32 x 1
17	015660	1	S.H.C.S. 10-24 x 1/2	60	500963	1	End Plug
18	501169	1	Piston	61	500955	1	Belt Hook
* 19	405430	1	O-Ring, Piston	62	092037	4	Lock Nut 10-32
20	404274	1	Washer	63	097748	1	Spring, Valve Pin
* 21	403594	1	Driver Blade	64	097746	1	Valve Pin
* 22	402725	1	Seal, Sleeve	* 65	092174	1	O-Ring, Valve Body
23	405243	1	Flange, Sleeve	66	026133	2	Roll Pin, 1/8 x 1
24	500952	1	Sleeve	67	401958	1	Valve Body
* 25	402728	1	O Ring, Sleeve	68	402668	1	Retaining Washer
* 26	091966	1	O Ring, Sleeve	69	501008	1	Lever, Bump Trigger
* 27	500369	1	O-Ring, Sleeve	70	501010	1	Bump Trigger
* 28	500975	1	Gasket, Cap	71	501009	1	Roll Pin
29	501140	1	Logo, Housing L	72	402669	1	Pin, Trigger
30	500957	1	Housing	73	500972	1	Rail Cover Assembly
31	501141	1	Logo, Housing R	74	403713	1	Retaining Ring
32	402708	1	Gasket, Nose Flange	75	500968	1	Rail Assembly
* 33	500950	1	Bumper	76	009397	2	S.H.C.S. 10-24 x 1/2
34	403705	1	Seal, Driver Blade	77	501142	1	Nameplate
35	402706	1	Flange	78	091536	1	Spring, Follower Latch Pin
36	091545	4	S.H.C.S. 1/4-20 x 7/8	79	403711	1	Latch Pin, Follower
37	402629	1	Hardened Washer	80	094295	1	O-Ring
38	405076	1	Spring	81	403710	1	Roller, Negator
39	403716	3	S.H.C.S. 10-32 X 5/16	82	403708	1	Negator Assembly
40	403712	1	Front Guide Latch Assembly	83	403715	1	Follower Assembly
41	501133	1	Rail Bracket Assembly	84	501139	1	Follower Tab
42	401988	1	Spring, Front Guide Latch	85	500973	2	Wear Strip
				86	501039	1	Sequential Trigger

\* Denotes Normal Wear Items.

\*\* Make sure Warning Label (500458) is properly affixed.

Replace if necessary.

Label available at no charge through the Service Parts Dept.

▲ Apply Loctite 242 (Blue) Part No. 093500.

→ Denotes New Change

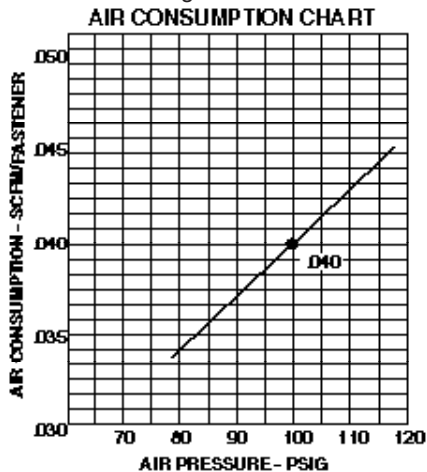

## SAFETY INSTRUCTIONS

### WEAR EYE AND HEARING PROTECTION



Always wear hearing protection and eye protection devices, including side shields when operating or working in the vicinity of a tool.



### DO NOT EXCEED MAXIMUM RECOMMENDED AIR PRESSURE

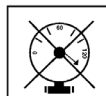

Operate the tool using only the recommended air pressure. Do not exceed the maximum air pressure marked on the tool. Be sure the air pressure gauge is operating properly and check it at least twice a day.

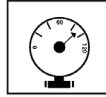

Never use any bottled air or gases such as oxygen to operate the tool since they could cause the tool to explode.

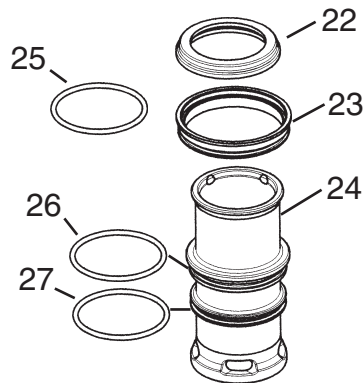
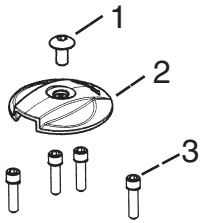

Cap Assembly  
#500974

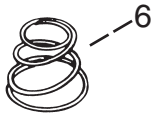
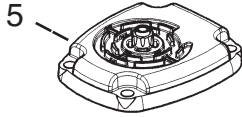

Main Valve  
Assembly #404188

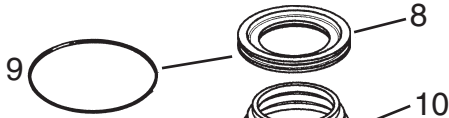

Piston Assembly  
#501583

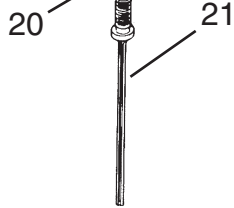
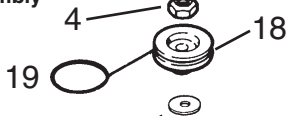

**OPTIONAL:**

Bump  
Trigger  
Assembly  
#501048

Exploded view of the optional bump trigger assembly showing parts 69, 70, and 71.

**⚠ WARNING**  
All parts must be periodically inspected and replaced if worn or broken. Failure to do this can affect the tool's operation and present a safety hazard.

# ACCESSORIES

## Back Plate Insert

This insert accommodates 1 1/4" and shorter finish nails.  
Also prevents nails from tumbling and jamming.

Part No. 1X1210

## Lubricants and Loctite

Loctite 242 (Blue)  
Lubricating Oil 16 oz.  
Lubricating Oil with Antifreeze 8 oz.  
Chemplex 710 Lubricant 1lb.



Part No. 093500  
Part No. 403720  
Part No. 219090  
Part No. 403734

## Degreaser Cleaner

Ideal cleaner for all Paslode tools.



Part No. 219086

## Safety Glasses

Clear



Part No. 402510

## Tool Case

Handy carrying case that conveniently stores your tool  
with room for additional accessories.

Part No. 501152

## 3-Strip Capacity Magazine Assembly

Offers the flexibility to increase the tool's magazine  
capacity to 150 nails.

Part No. 219271

→ 1/4" Swivel Air Fitting

Part No. 501506



An Illinois Tool Works Company  
888 Forest Edge Drive  
Vernon Hills, Illinois 60061-3105