

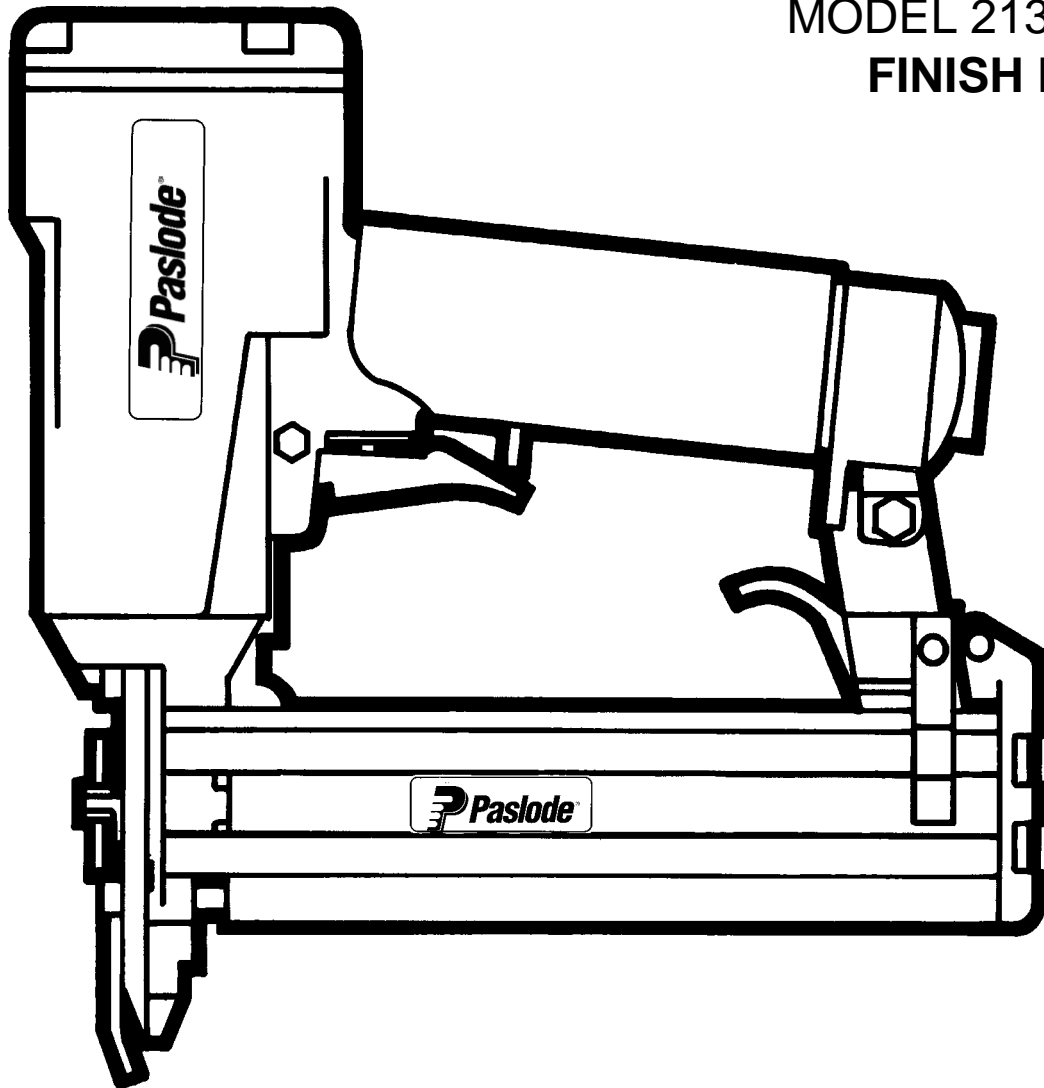

MODEL 2138-F18 II
FINISH NAILER



TOOL SCHEMATIC AND PARTS

IMPORTANT!
DO NOT DESTROY

Always refer to operating manual #403606 for detailed information on this tool. It is the customer's responsibility to have all operators and service personnel read and understand this information.

PARTS LEGEND

MODEL 2138 - F18 II, 500181

MODEL 2138 - F18 II, 500181(Europe)

▲ 1	004174	4	Socket Head Cap Screw, 10-24x7/8"	41	500122	1	Lever, Trigger
2	004238	4	Washer, Split Lock 10	42	500196	1	Roll Pin, 1/8 x 9/16
3	500104	1	Cap	43	404325	2	Nut, Stop, 8-32
4	500109	1	Bumper, Valve	44	500121	1	Trigger
*5	500106	1	Gasket, Cap	45	500395	1	Handle Wrap, Service
6	500105	1	Cap, Inner	46	500401	1	Magazine and Label Assembly
7	500107	1	Gasket, Housing	47	500132	1	Back Plate
8	500110	1	Spring, Main Valve	48	500388	1	Nose Seal
*9	097529	1	O-Ring, Valve, 111	▲49	500163	2	Screw, Shoulder, 1/4 x 1-1/4"
*10	401951	1	O-Ring, Valve, 126	50	500406	1	Muffler
11	500111	1	Valve, Main	51	500277	1	Front Plate
*12	500194	1	O-Ring, Valve, Urethane 217	52	500278	1	Shear Plate
13	500195	1	Nut, Low Profile Lock, 1/4-28	53	500199	2	Spring, Quick Clear
*14	092774	1	O-Ring, Piston 213	54	500140	1	Follower
15	500294	1	Piston	55	500404	1	Washer, Negator Bracket
*16	500114	1	Driver Blade	56	500136	1	Wear Strip
*17	091540	1	O-Ring, Return 130	57	500204	1	Bushing, Negator
18	500586	1	Sleeve	58	500203	1	Spring, Negator
*19	402723	1	O-Ring	59	500139	1	Bracket, Negator
*20	500334	1	Bumper	60	500403	1	Pin, Negator Bracket
21	402079	1	Screw, Pan Head Shoulder	61	500272	1	Cover, Magazine
22	500198	1	Spring, Work Contacting Element	62	500290	1	Plate, Latch
▲23	015660	1	Button Head Cap Screw, 10-24 x 1/2"	63	402668	1	Washer, Retaining
▲24	009397	4	Socket Head Cap Screw, 10-24 x 1/2"	64	402743	1	Pin
25	402629	1	Washer, Hardened	65	500291	1	Bracket, Stop
26	500282	1	Upper Work Contacting Element	66	091191	1	Locknut
27	500288	1	Washer	67	500292	1	Bracket, Magazine
28	500289	1	Washer	68	500295	1	Latch
29	500124	1	Bushing, Work Contacting Element	69	500143	1	Spring, Latch
30	004958	2	Roll Pin, 1/8 x 7/8"	**70	500492	1	Warning Label
31	500117	1	Housing	405512	1	Fastener Label (Europe)	
32	500108	1	Gasket, End Cap	71	500307	1	Window
33	500119	1	Sleeve, End	72	500229-01	1	Nameplate, F18
*34	090927	1	O-Ring 117	73	500236	1	Screw 8-32 x 1
35	500118	1	End Plug	74	500404	1	Washer Negator Bracket
36	091622	1	Bushing, Reducing Pipe	75	405550	1	CE Label (Europe)
37	097748	1	Spring, Valve Pin	76	008731	4	Socket Head Capscrew 10-24 x 3/4
38	097746	1	Pin, Valve	77	500587	1	Sleeve Insert
*39	092174	1	O-Ring, Valve Body	78	092043	1	O-Ring
40	401958	1	Valve Body	79	500606	2	Housing Logo Label

* Denotes Normal Wear Items

** Make sure Warning Label (500492) is properly affixed. Replace if necessary. Label available at no charge through the Service Department.

▲ Apply Loctite 242 (Blue) Part No. 093500.

➔ Denotes New Change

⚠ WARNING

All parts must be periodically inspected and replaced if worn or broken. Failure to do this can affect the tool's operation and present a safety hazard.

AIR CONSUMPTION CHART

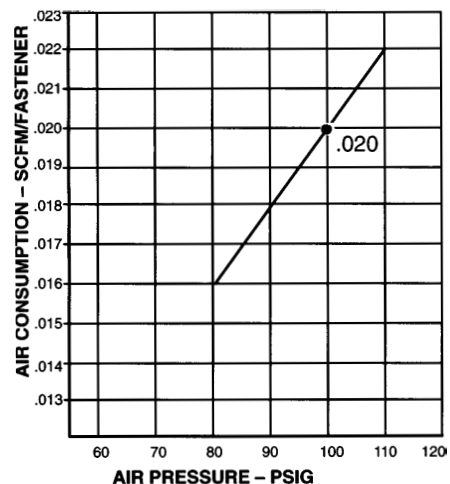

ACCESSORIES

Lubricants and Loctite

Chemplex 710 Lubricant 1 lb.	Part No. 403734
Chemplex 710 Lubricant 5 gram tube	Part No. 219188
Loctite 242 (Blue) 1 oz.	Part No. 093500
Lubricating Oil 8 oz.	Part No. 219026
Lubricating Oil with Antifreeze	Part No. 219090

Remote Fire Valve

This valve via an air signal allows the machine mounted tool to be operated from an automatic or foot pedal system.

Part No. 1X0713

Degreaser Cleaner

Ideal cleaner for all Paslode tools

Part No. 219086

Safety Glasses

Clear
Tinted

Part No. 402510
Part No. 402412

SAFETY INSTRUCTIONS

WEAR EYE AND HEARING PROTECTION

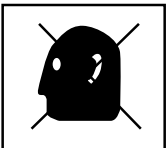

Always wear hearing protection and eye protection devices, including side shields when operating or working in the vicinity of a tool.



Never use any bottled air or gases such as oxygen to operate the tool since they could cause the tool to explode.

DO NOT EXCEED MAXIMUM RECOMMENDED AIR PRESSURE

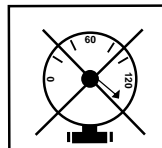

Operate the tool using only the recommended air pressure. Do not exceed the maximum air pressure marked on the tool. Be sure the air pressure gauge is operating properly and check it at least twice a day.

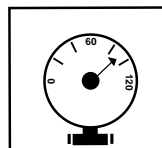

An Illinois Tool Works Company
888 Forest Edge Drive
Vernon Hills, Illinois 60061-3503